

## YOUR BENEFITS

A digital twin provides you and your clients considerable options throughout a product's entire life cycle. This model serves as a central collaboration platform and a common basis for communication. Software support additionally provides a wide variety of value added, e.g. control system development on the model and integrated functional tests during engineering as well as worker assistance, and assistance with troubleshooting and data acquisition during system operation and maintenance. A digital twin developed using the Fraunhofer IFF's methods centrally structures the data acquired in every unit of a company. This makes all of a system's data directly available anywhere and anytime and the digital twin a custom database of knowledge acquired during process optimization, e.g. with simulations. Processes throughout the value chain can be coordinated efficiently and organized transparently and your company can prepare itself for the future.

### Our Products and Services at a Glance

Comprehensive consulting and support for integrated virtual engineering and system operation with a digital twin, especially in the following areas:

#### Tools and methods for modeling and digitally transforming your engineering

- Workshops on digitizing your engineering
- Implementation of VINCENT including training

#### Process analysis and optimization and training

- Engineering checkup
- Management game on agile engineering with a digital twin

#### Creating your own value added with a digital twin

- ASSIST scalable assistance system

### FRAUNHOFER INSTITUTE FOR FACTORY OPERATION AND AUTOMATION IFF

Director  
Prof. Michael Schenk

Sandtorstrasse 22  
39106 Magdeburg  
Germany

Phone +49 391 4090-0  
Fax +49 391 4090-596  
ideen@iff.fraunhofer.de  
www.iff.fraunhofer.de

#### Contact

Virtual Engineering  
Prof. Ulrich Schmucker  
Phone +49 391 4090-201  
Fax +49 391 4090-250  
ulrich.schmucker@iff.fraunhofer.de

[www.iff.fraunhofer.de/ve](http://www.iff.fraunhofer.de/ve)

## THE DIGITAL TWIN: GUARANTEEING YOUR SUCCESS



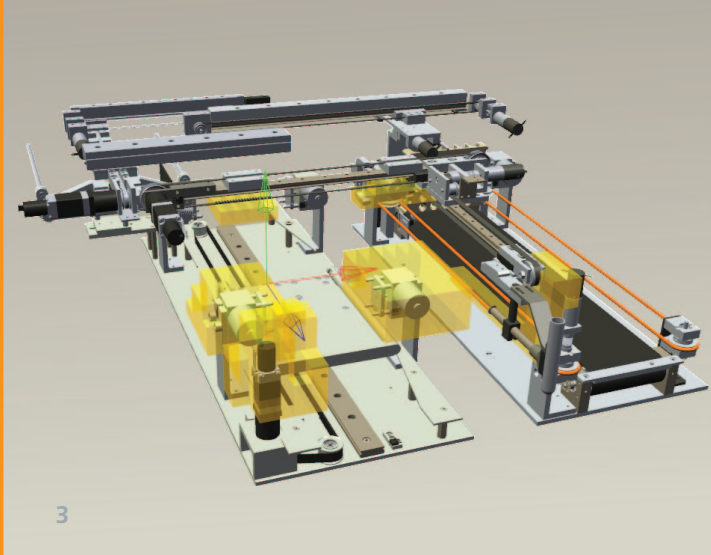
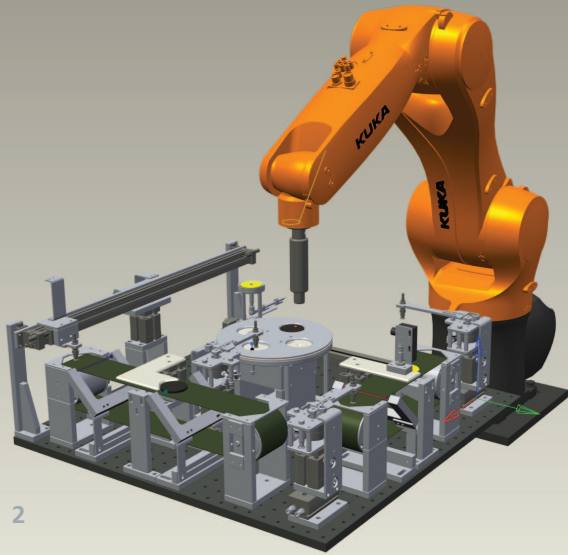
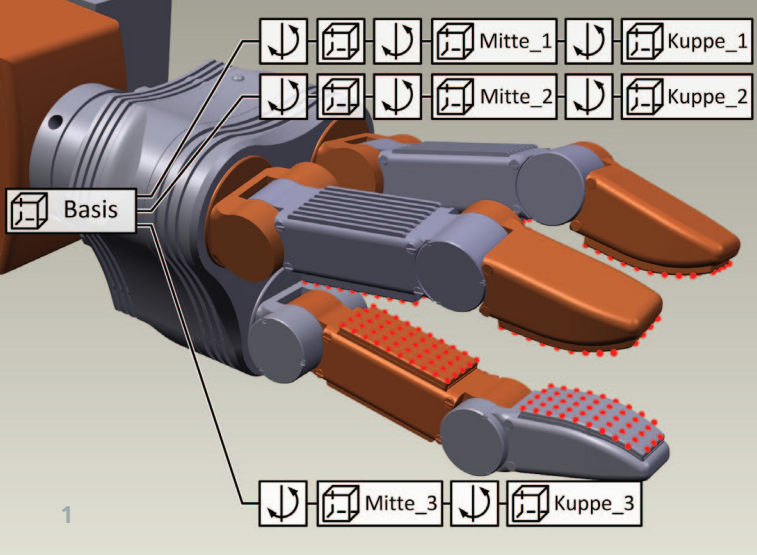

## WHAT IS A DIGITAL TWIN?

The Fraunhofer IFF has years of experience in virtual system development. The virtual engineering methods and tools we have developed enable companies to develop systems digitally and optimize processes throughout the entire life cycle. Our research institute has used these methods in development projects of our own, thus demonstrating their benefits in the field.

Building upon this, the Fraunhofer IFF is implementing a new idea in virtual system development: A digital twin is a dynamic model of a system, which replicates the system's state in real time. This model is used to obtain knowledge and generate value added from the system's data.

The methodology uniquely integrates capabilities, functions and unique identification of components in the model in a structured form. This is the key to creating an actual "twin" of reality. It can also be integrated, i.e. throughout the entire product life cycle from the idea through operation and beyond.

Rather than merely capturing data in a structured form, the tools and methods fully replicates the manufacturing world digitally. In the future, system manufacturers will be able to deliver a unique and functional digital model with every real manufacturing system. This will enable them to offer their clients considerable value added such as virtual inspections and tests, new forms of operating assistance, and digital optimization.

At the same time, system manufacturers also profit internally: One central model enables them to organize development processes more flexibly and efficiently and validate them better. What is more, this digital world provides additional capabilities to collect and analyze data and thus to explore new, individual business models.

## OUR CONSULTING AND SOFTWARE SUPPORT SERVICES

The Fraunhofer IFF provides a comprehensive range of virtual engineering consulting services and products, including a modular software package with a complete methodology for efficient creation and integrated use of digital twins. Its main features are:

### Compatibility

Our tools can largely be integrated in your existing software landscape without having to modify engineering tools already in place.

### Uniqueness

Our system uniquely identifies relevant parts.

### Individuality

The methodology for the development of digital twins can be scaled based on your own objectives. This is facilitated by the modular structure of the software package and methodological toolkit.

### Integration

Software support is integrated in the system's life cycle from development through operation. This expanded base of data provides considerable potential for new business models and greater client retention.

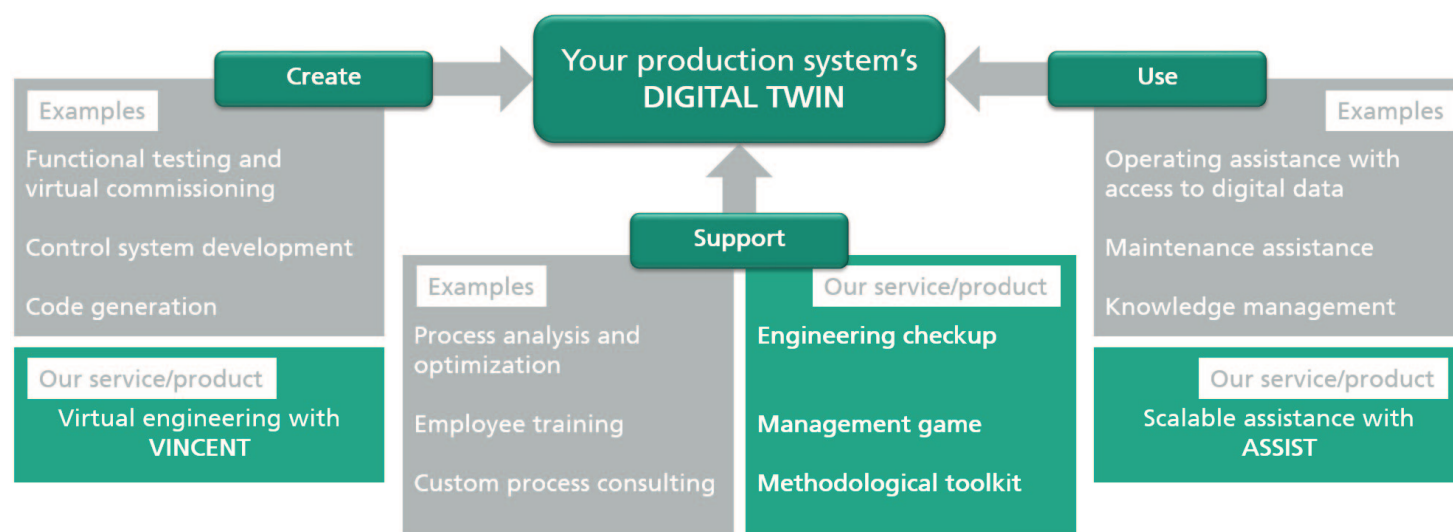

1 – 2 Kinematics design and material flow in VINCENT.

3 Control system development directly on the model

4 ASSIST assistance system in system operation